

# Capacity & Unbalanced Load Information for Heavy Duty (HD) Wall & Island Shelving

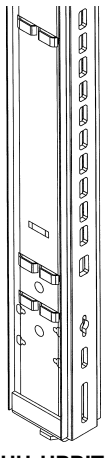

The Heavy Duty (HD) Wall and Island Shelving has more unbalanced load capacity than the standard shelving as shown in the "Unbalanced Load Calculations" on page 1B of "Display Shelving Installation Instructions" (01-13).

The Heavy Duty Low Base system has an unbalanced load capacity of 18,000 inch-pounds and the Heavy Duty 06 Base system has an unbalanced load capacity of 20,000 inch-pounds as compared with the standard capacity of 12,000 inch-pounds.

Follow the procedure shown below for calculating the "unbalanced load" on the Heavy Duty Wall or Island Shelving.

## HEAVY DUTY UPRITE

The Universal Heavy Duty Upright (UH) will accept either an 06 Base Bracket or a Low Base Bracket. A 2-7/8" overall depth and an insert in the bottom of the Upright increase the unbalanced load capacity to 20,000 in lbs (06), 18,000 in lbs (LB).

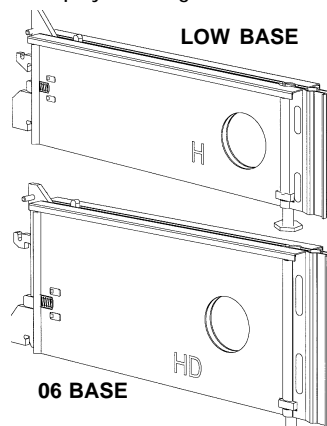

**WARNING:** These Heavy Duty capacities are only available when Heavy Duty Uprights and Base Brackets are used together. **DO NOT** mix Heavy Duty and Standard components.

**IMPORTANT:** Use Display Shelving Installation Instructions (01-13) for the remainder of the installation procedure. There are specific procedures for Removable Base Brackets.

## HEAVY DUTY BASE BRACKET

06 Base and Low Base Heavy Duty Base Brackets are available in depths from 22" through 31". All are removable style. Heavy gauge steel and a double thick hook combine to make this our strongest bracket. For easy identification, an "H" or "HD" is stamped in the side of the Base Bracket.

## UNBALANCED LOAD CALCULATIONS FOR HEAVY DUTY SHELVING

When heavily loading one side of your wall or island shelving, it is important to determine if you are creating an unbalanced load that exceeds the maximum allowable. The sample calculation below illustrates how you can determine your unbalanced load in inch-pounds.

**NOTE:** Inch-pounds are a measure of the shelf loads acting at a distance (1/2 shelf depth) from the Upright.

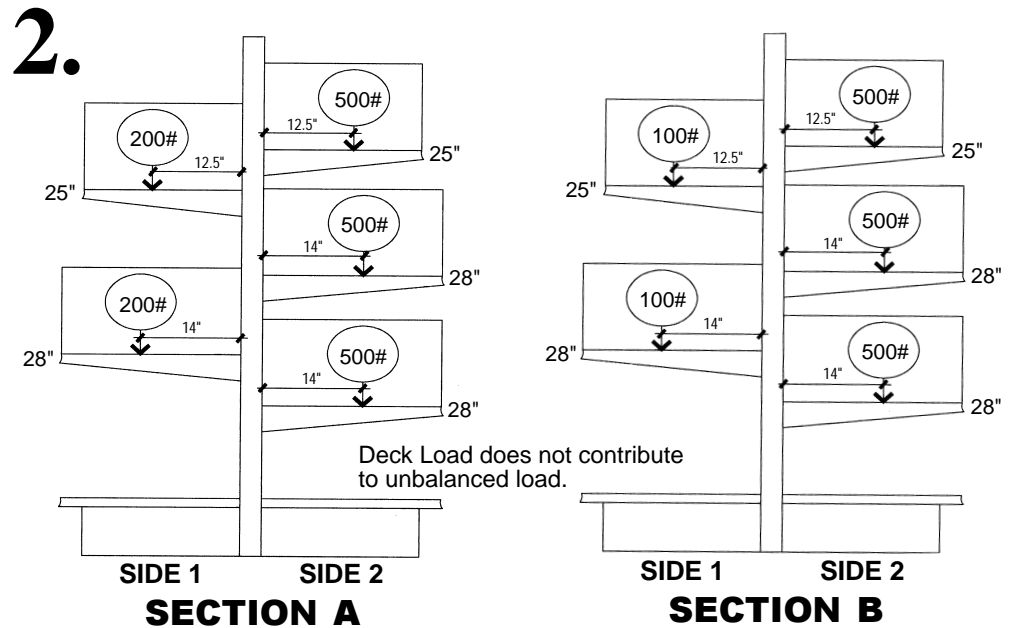
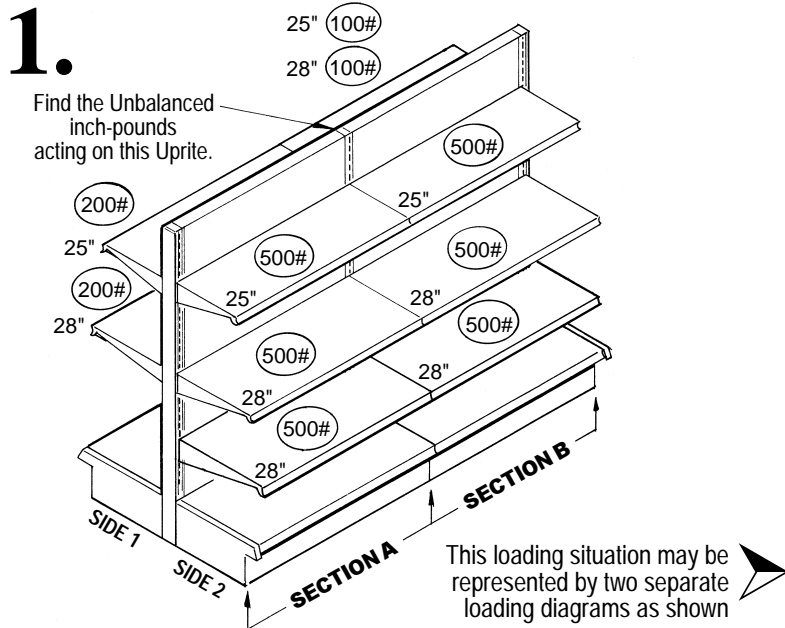

**3.** NOTE: Shelf depth is divided by 2 because an evenly distributed shelf load is calculated as a total load at center of shelf depth. Shelf load is divided by 2 because a shelf load is supported by two uprights.

### WALL SECTION UNBALANCED LOAD CALCULATION:

The method used to determine the unbalanced inch-pounds on a wall section is the same as the method shown for an island section. Simply consider the side without shelves having a load of zero.

**NOTE:** See Wall Section Warnings at the bottom of this page.

	(Shelf depth ÷ 2)	x	(Shelf load ÷ 2)	=	SIDE 1	SIDE 2
SECTION A	12.5"	x	100#	=	1250" #	
	14"	x	100#	=	1400" #	
	12.5"	x	250#	=		3125" #
	14"	x	250#	=		3500" #
	14"	x	250#	=		3500" #
SECTION B	12.5"	x	50#	=	625" #	
	14"	x	50#	=	700" #	
	12.5"	x	250#	=		3125" #
	14"	x	250#	=		3500" #
	14"	x	250#	=		3500" #
<b>TOTAL (Section A and B)</b>					<b>3975" #</b>	<b>20250" #</b>

Subtract the smaller unbalanced load from the larger: 20250 inch-pounds - 3975 inch-pounds = 16275 inch-pounds

**NOTE:** " # indicates inch-pounds.

This is the total unbalanced load acting on the upright and must never exceed 18,000 inch-pounds for HD Low Base or 20,000 inch-pounds for HD 06 Base.

**CAUTION:** In this example, 16,275 inch-pounds does not exceed either the 18,000 inch-pound limit for HD Low Base or the 20,000 inch-pound limit for HD 06 Base. However, note that the total of Sections A and B on Side 2 is 20,250 inch-pounds. This means that Side 2 would exceed the limits for Heavy Duty Low Base and 06 systems if loaded before Side 1, or if Side 1 was unloaded before Side 2. Therefore, on this example, Side 1 should be loaded before Side 2, and Side 2 should be unloaded to less than 18,000 inch-pounds for HD Low Base and 20,000 inch-pounds for HD 06 Base before unloading Side 1.

**DO NOT EXCEED 18,000 INCH-POUNDS UNBALANCED LOAD FOR HEAVY DUTY LOW BASE SYSTEMS. DO NOT EXCEED 20,000 INCH-POUNDS UNBALANCED LOAD FOR HEAVY DUTY 06 BASE SYSTEMS.**

## SPECIAL WARNINGS:

**EXTENSION UPRITES** - The maximum unbalanced load on shelves above the joint on an Extension Upright should not exceed 2500 inch-pounds.

**PEGBOARD BACK LOADS** - The loads applied to Pegboard Backs should not exceed 150 lbs. on one side of a section with a standard Bottom Rail (150 lbs. per side for Double Backs) and 300 lbs. on one side (300 lbs. per side on Double Backs) with a heavy duty Bottom Rail.

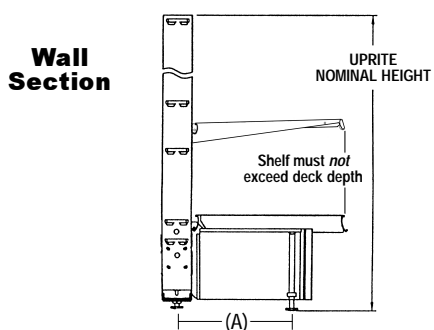

WALL		
BASE SIZE	LEVELER SPACING(A)	TALLEST UNANCHORED UPRITE
13"	9 3/4"	54"
16"	12 3/4"	72"
19"	15 3/4"	90"
22"	18 3/4"	108"
25"	21 3/4"	120"
28"	24 3/4"	144"

**NOTE:** For Upright applications taller than 144", contact Marketing.

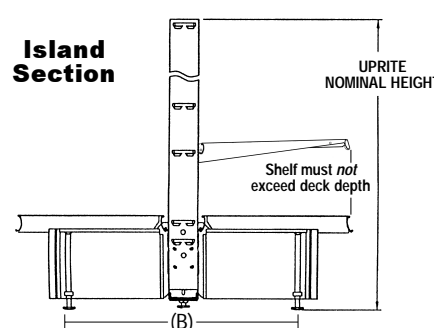

ISLAND		
BASE SIZE	LEVELER SPACING(A)	TALLEST UNANCHORED UPRITE
13"/13"	19 1/2"	114"
13"/16"	22 1/2"	132"
13"/19"	25 1/2"	144"
16"/16"	25 1/2"	144"

**NOTE:** For Upright applications taller than 144", contact Marketing.

To help avoid overturning:

- The height of the Upright (including Extension Uprights, if used) should not exceed the leveler spacing times six. See the charts.
- If Uprights on Wall Sections exceed the heights listed, the Base Bracket and the Upright levelers must be anchored to the floor or otherwise braced. See Display Shelving Instructions 01-13.
- If Uprights on Gondola (Island) Sections exceed the heights listed, the Base Bracket levelers must be anchored to the floor and the Base Brackets must be secured to the Uprights with SAP pins.
- Contact local building official for anchoring requirements in seismic zones.
- Maximum shelf depth **cannot** exceed Base Deck depth.
- Do **not** hang Peg Hooks, Shelves, or other accessories on the back side of a Wall Section or any section without Base Brackets. Wall Sections do not have Base Brackets on the back side to provide support, and use of the back side to display merchandise may cause the section to tip over.
- Do **not** lean tall or heavy items against shelving unless shelving is anchored to a suitable building wall, to the floor, or otherwise braced to prevent overturning. The weight and force of leaning items on unanchored or unbraced shelving may cause the shelving to overturn or collapse.

**IMPORTANT!** Failure to follow these instructions and warnings may result in personal injury to your employees or customers, damage to property, or damage to the fixture itself.

### Floor Anchoring

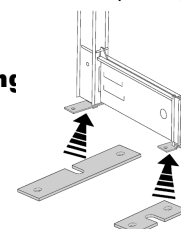

### Important Notice for Free Standing Units

- If Glass Doorkits are used on Wall Section or on one side only of Island Section, reduce maximum height by 12"
- If fixture is on carpet, reduce maximum height by 12"



Call Toll-Free 800-228-9882 • (Canada - Call Toll Free 800-248-6930)