

**Mobile Gondola Kit:**

- Converts a Display Shelving Island into a Mobile Island
- Each Kit contains:  
Mobile Gondola CBFs w/Casters  
Low Base Base Brackets  
Base End Trims  
Mobile Gondola Top Rail hold down (alternating sections)
- Order Display Shelving Islands, sections, & ends separately (pg 105)  
Delete Closed Base Fronts, Base Brackets, &  
Base End Trims from each Section
- Overall deck height similar to standard 06 base height
- **For pricing see section 100, pg 71**

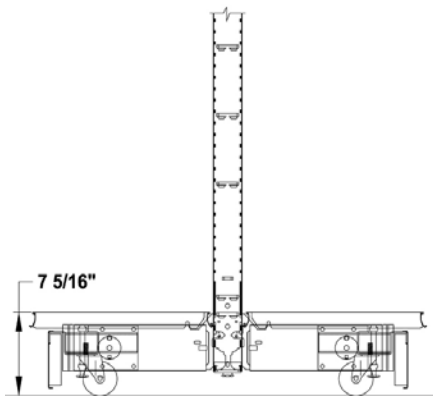
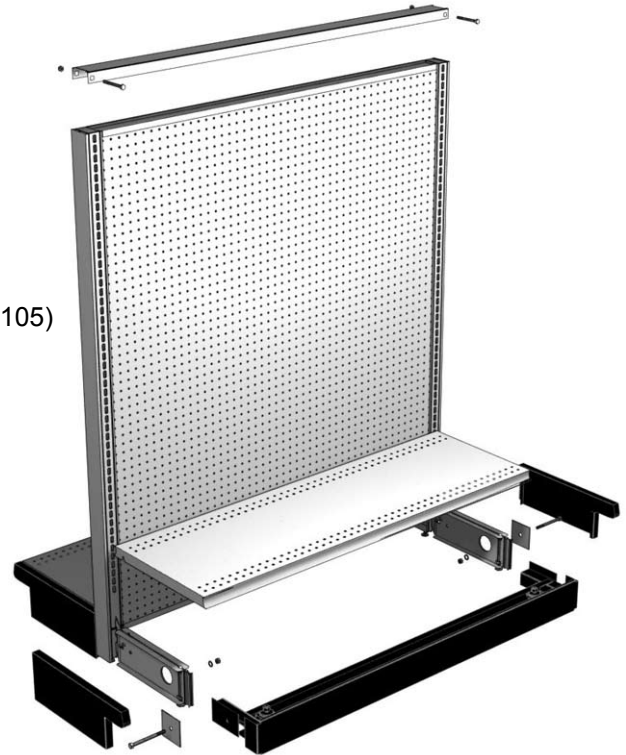

**Low Base Mobile Gondola**

**Order Notes:**

- Maximum Display Shelving Upright height = 78"
- Maximum of 3 Sections per run
- Uniformly distributed load of 1,000 lb. per section

Run Length	Section Combination
3'	3'
4'	4'
6'	3' + 3'
7'	4' + 3'
8'	4' + 4'
9'	3' + 3' + 3'
10'	3' + 4' + 3'
11'	4' + 3' + 4'
12'	4' + 4' + 4'

**EXAMPLE PART NO.**

**MGK 4 1616 U**

- MGK** = Mobile Gondola Kit  
**4** = Run Length:  
 3', 4', 6', 7', 8', 9', 10', 11', 12'  
**1616** = Deck combinations:  
 1616, 1919, 2222, 2525  
**U** = Unit

**STANDARD FINISH:**

**PLT CHR**

- PLT** • Top Rail Hold Down  
 • Optional Tier I & II colors  
**CHR** • Closed Base Front, Base  
 End Trim, & Base Bracket