

# Upright Accessories

## Upright/Base Bracket Anchor Plates

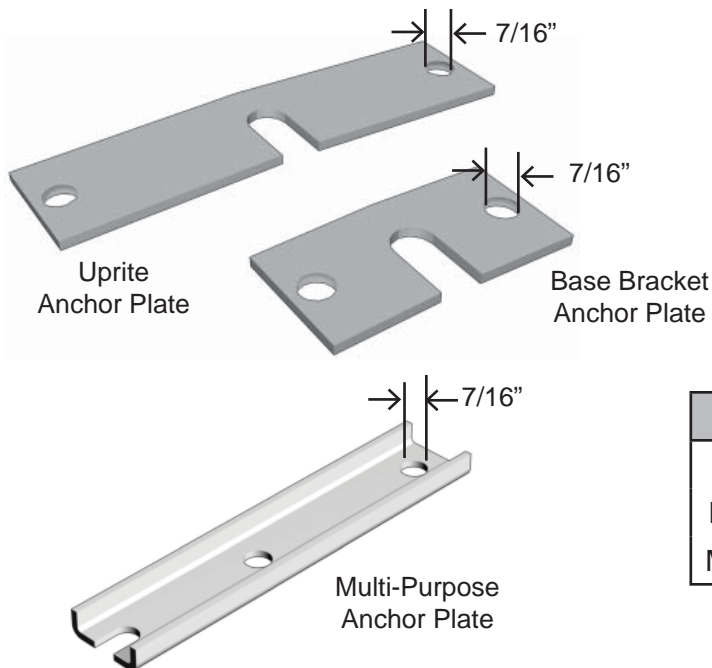

### Anchor Plates

- Anchor Plates used when Shelving Unit exceeds height to depth ratio limits
- Required for Shelving over 5'H in certain seismic zones (Contact local building officials for fastener requirements)
- Accepts 1/4" or 3/8" dia. anchor bolts
- Secures Leveling Leg to floor using anchor bolts (not included)
- Multi-Purpose Anchor for end of run, Wall End Display or limited access applications
- **For pricing see section 100, pg 88**

DESCRIPTION	PART NO.
Upright Anchor Plate	DC1241
Base Bracket Anchor Plate	DC1242
Multi-Purpose Anchor Plate	DC1248

### STANDARD FINISH:

**GLV**

- Galvanized

## Wall-Mount Upright

### Wall-Mount Upright:

- Slotted 1" on center
- Attaching hardware not included
- WMU actual size is 1" shorter than nominal size
- **For pricing see section 100, pg 88**

### EXAMPLE PART NO.

**WMU 48**

WMU = Wall Mounted Upright  
48 = Height: 48", 60", 72", 84", 90"

### STANDARD FINISH:

**PLT**

- Optional Tier I & II colors



### Wall-Mount Bracket:

- Connect standard Uprights to building walls
- Two Brackets are required for Uprights to 96"H  
 Three Brackets for one piece Uprights over 96"H
- Extension Uprights require one Bracket for Uprights to 36"H; two for Extensions over 36"
- Fasteners not included
- **For pricing see section 100, pg 88**

PART NO.  
**DC2191**

### STANDARD FINISH:

**GLV**

- Galvanized

## Wall-Mount Bracket

