

# Extended Shelf Assembly & Bin System

## TL-Style Extended Shelf Assembly:

- Includes one Shelf & two zinc Mounting Brackets
- Mounting Brackets attach Extended Peg Panels
- Two Shelves minimum per Panel recommended
- To add Aluminum Tag Molding (pg 221) replace "N" at end of Shelf part number with molding style
- Order Extended Pegboard Panel separately
- **For pricing see section 400, pg 5**

## TL-Style Extended Shelf Assembly

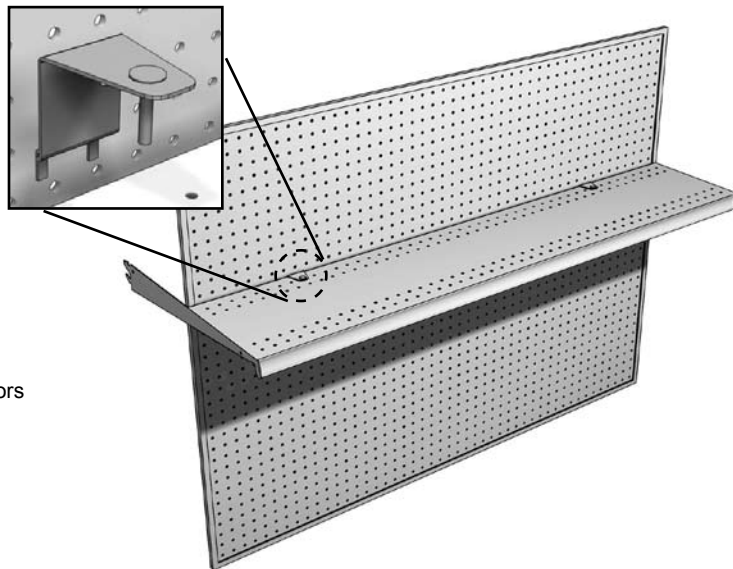

### EXAMPLE PART NO.

TXP	4	10	19	N
-----	---	----	----	---

- TXP = TL-Style Extended Shelf  
 4 = Width  
 10 = Shelf top depth  
 19 = Bracket depth: 19" or 22"  
 N = No Aluminum Molding  
 • Molding M13\_ or M35\_  
 Specify: "S" Satin or "G" Gold

### STANDARD FINISH:

PLT
-----

- Optional Tier I & II colors

## Plastic Bin System:

- Used to merchandise small items, 3"H & 5"H Bins install on Mounting Bar
- 7"H Bins recommended for self stacking only
- Specify desired Bin color
- **For pricing see section 400, pg 5**

### Bins



Depth	Width	Height	Part No.
5 3/8"	4 1/8"	3"	HB1341
7 3/8"	4 1/8"	3"	HB1342
10 7/8"	5 1/2"	5"	HB1343
14 3/4"	8 1/4"	7"	HB1344
14 3/4"	16 1/2"	7"	HB1345

### Standard Finish:

- XA1 (Blue Polypropylene)
- XA2 (Yellow Polypropylene)
- XA3 (Red Polypropylene)

## Plastic Bin System

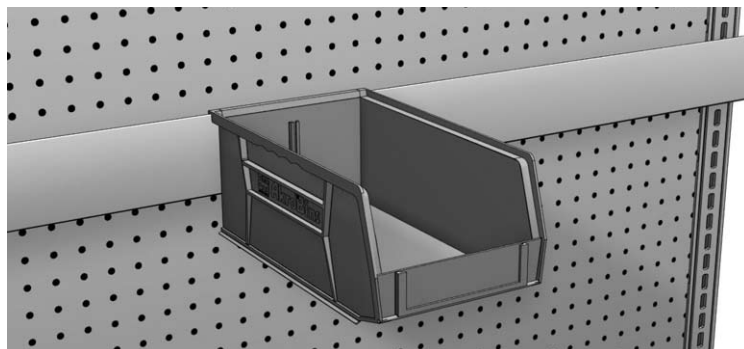

## Mounting Bars

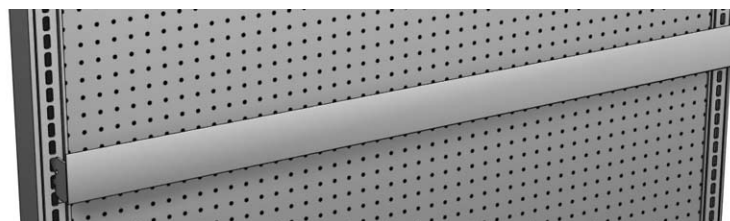

WIDTH	PART NO.
3'	HB1111
4'	HB1112

### STANDARD FINISH:

PLT
-----

- Optional Tier I & II colors